

FPD2-0-18000-10

2-Way, DC~18GHz, 10W

Features:
 * Small Size
 * Low Insertion Loss

Applications:
 * Amplifiers
 * Mixers
 * Antennas
 * Laboratory Test

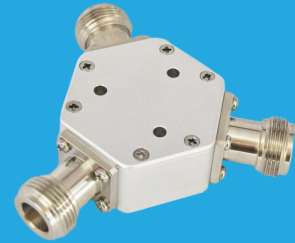

Electrical

Frequency:	DC~18GHz
Insertion Loss:	1.5dB max.
VSWR:	1.5 max.
Isolation:	5.5dB min.
Amplitude Balance:	±1.2dB
Phase Balance:	±10°
Impedance:	50Ω
Average Power:	10W

Mechanical

Connectors: N Female

How To Order

FPD2-0-18000-10-Y

Y: Connector type

Connector naming rules:

N - N Female (Outline A)

Examples:

To order a 2-way power divider, 0~18GHz, 10W, N female, specify FPD2-0-18000-10-N.

Customization is available upon request.

Environmental

Operating Temperature:	-35~+75°C
Non-operating Temperature:	-45~+85°C

Outline Drawings

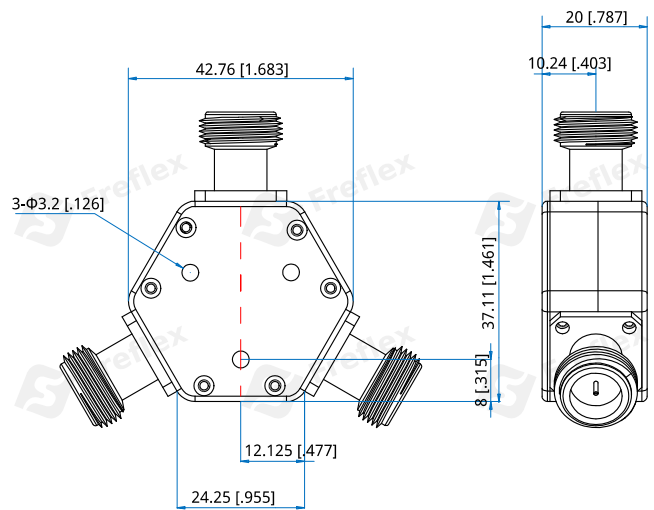

Outline A

Unit: mm [in]

Tolerance: ±0.5mm [±0.02in]

Typical Performance Curves

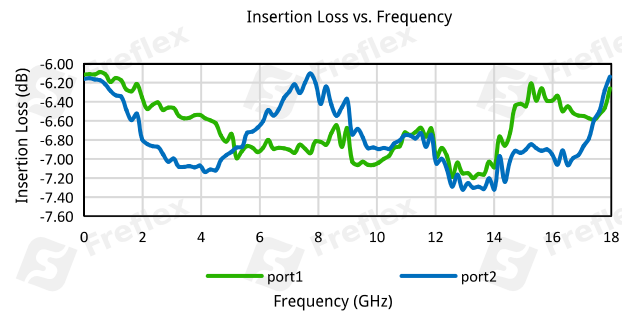
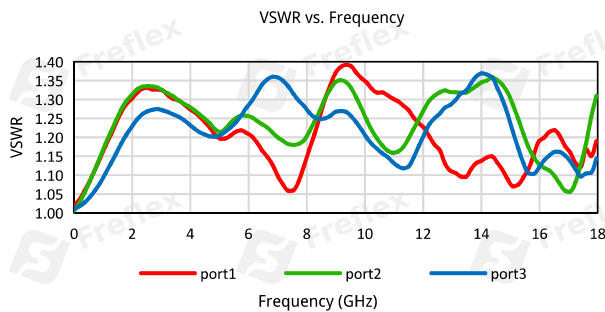

2-Way Resistive Power Divider

Isolation vs. Frequency

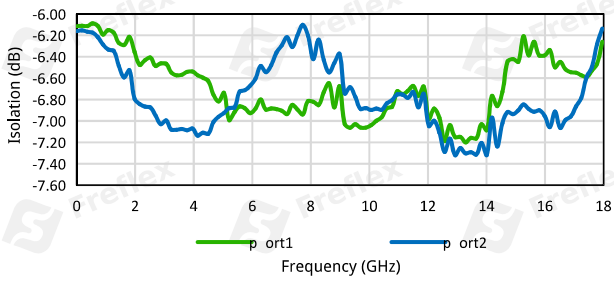

Amplitude balance vs. Frequency

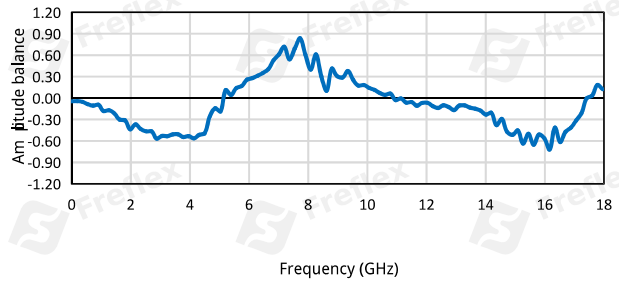

Phase balance vs. Frequency

