

FBM-18000-40000

18~40GHz

Features:

- * Low Conversion Loss
- * High Isolation

Applications:

- * Wireless
- * Transceiver
- * Laboratory Test
- * Broadcast

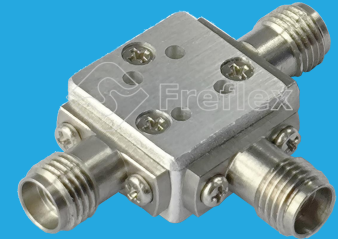

Electrical

RF Frequency:	18~40GHz
LO Frequency:	18~40GHz
LO Input Power:	+15dBm typ.
IF Frequency:	DC~22GHz
Conversion Loss:	7dB typ.
Isolation (LO, RF):	40dB typ.
Isolation (LO, IF):	30dB typ.
Isolation (RF, IF):	30dB typ.
VSWR:	2.8 typ.

Absolute Maximum Ratings*1

Input Power: +22dBm

[1] Permanent damage may occur if any of these limits are exceeded.

Mechanical

Size*2:	14*14*8mm 0.551*0.551*0.315in
IF Connectors:	SMA Female
RF/LO Connectors:	2.92mm Female
Mounting:	4*Φ1.8mm through-hole

[2] Exclude connectors.

Environmental

Operating Temperature:	-55~+85°C
Non-operating Temperature:	-65~+150°C

Typical Performance Curves

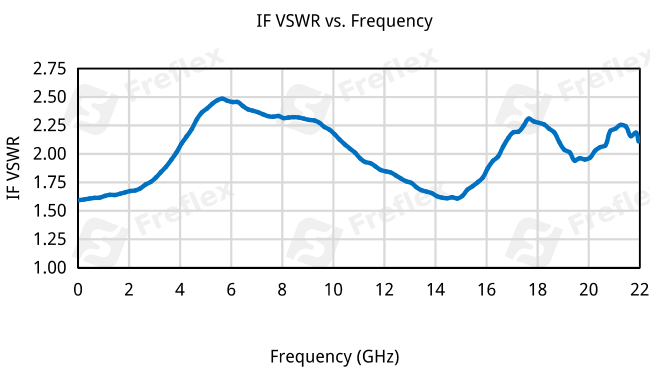

Outline Drawings

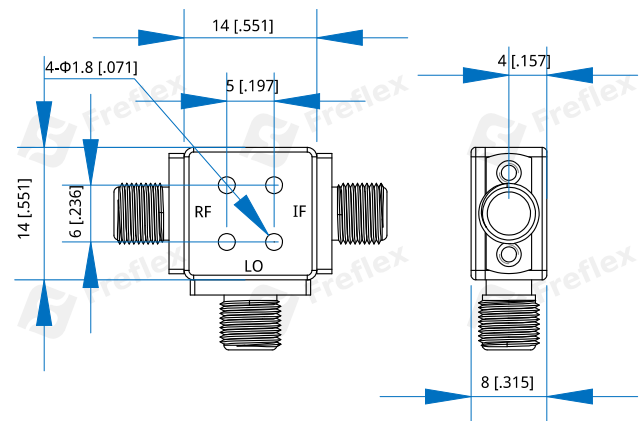

Unit: mm [in]

Tolerance: ±0.2mm [±0.008in]

How To Order

FBM-18000-40000

Customization is available upon request.

