

FCI5258E

High Power, High Isolation

Features:

- * High Power
- * High Isolation
- * Low Insertion Loss
- * Low VSWR

Applications:

- * Wireless
- * Radar
- * Laboratory Test

Description

FCI5258Eseries Coaxial Isolators cover frequency range 160~330MHz. High power, high isolation and low insertion loss make it ideal for a lot of applications like amplifiers, transceivers, etc.

Specifications

Frequency (MHz)	Bandwidth (MHz)	IL (dB Max.)	Isolation (dB Min.)	VSWR (Max.)	Fwd Power* ¹ (W Max.)	Rev Power (W)	Connector	Temperature (°C)
160~200	10	0.70	18.0	1.30	500	10~100	SMA, N	-30~+70
192~232	40	0.60	18.0	1.30	500	10~100	SMA, N	-30~+70
200~220	20	0.40	20.0	1.25	500	10~100	SMA, N	-30~+70
220~240	20	0.40	20.0	1.25	500	10~100	SMA, N	-30~+70
260~330	10	0.20	23.0	1.20	500	10~100	SMA, N	-30~+70
260~330	70	0.40	20.0	1.25	500	10~100	SMA, N	-30~+70

The size of the termination varies according to the reverse power

[1] The connector is SMA, and the maximum forward power can only reach 100W.

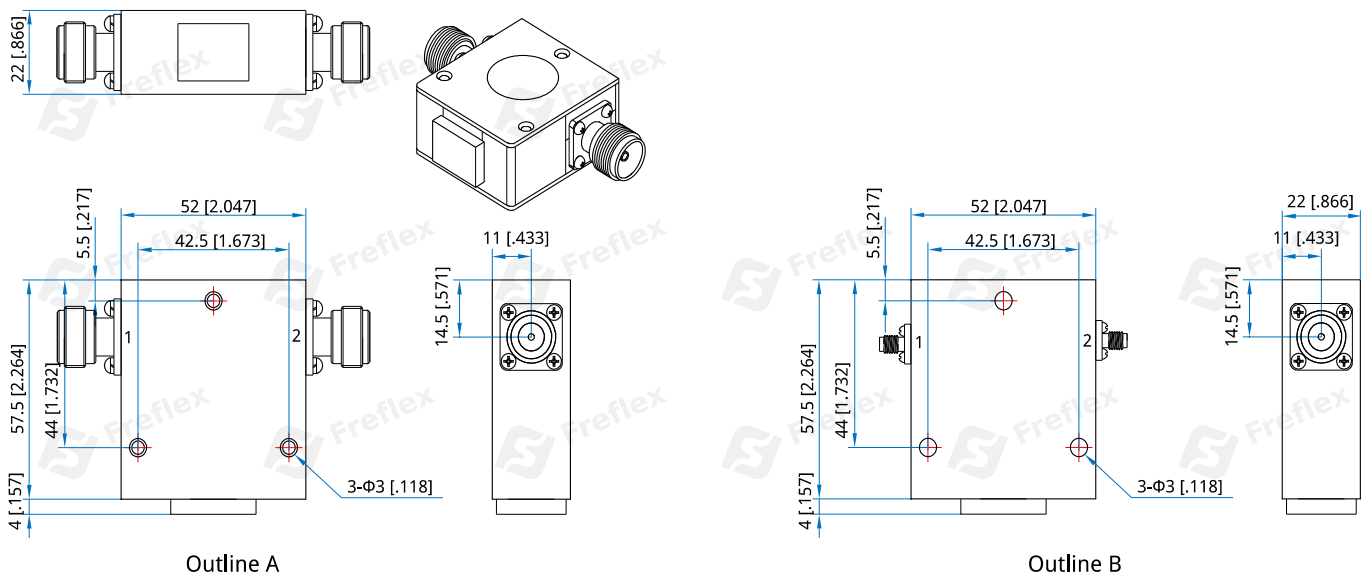
Outline Drawings

Unit: mm [inch]

Tolerance: $\pm 0.2\text{mm}$ [$\pm 0.008\text{in}$]

Mechanical

Size*2: 52*57.5*22mm
2.047*2.264*0.866in

Mounting: 3- Φ 3mm through-hole

[2] Exclude connectors and terminations.

Connector Naming Rules:

N - N Female (Outline A)

S - SMA Female (Outline B)

Direction Naming Rules:

1 - Clockwise

2 - Anticlockwise

How To Order**FCI5258E-U-V-W-X-Y-Z**

U: Start frequency in MHz

V: Stop frequency in MHz

W: Forward power in W

X: Reverse power in W

Y: Connector type

Z: Direction type

Examples:

To order a FCI5258E series Isolator, 170~180MHz, Forward power 500W, Reverse power 100W, N female, Clockwise, specify FCI5258E-160-200-K5-K1-N-1.

Customization is available upon request.