

FDPHA-33000-50000-10-2-1

33~50GHz, 10dB, 2.4mm

Features:
* Broadband

Applications:
* Wireless
* Transceiver
* Laboratory Test
* Broadcast

Electrical

Frequency: 33~50GHz
Gain: 10dB
VSWR: 1.4 max.
Isolation: 30dB min.
Polarization: Dual linear

Mechanical

Connectors: 2.4mm Female
Material: Copper
Finish: Silver-plating
Coating: Gray paint

Outline Drawings

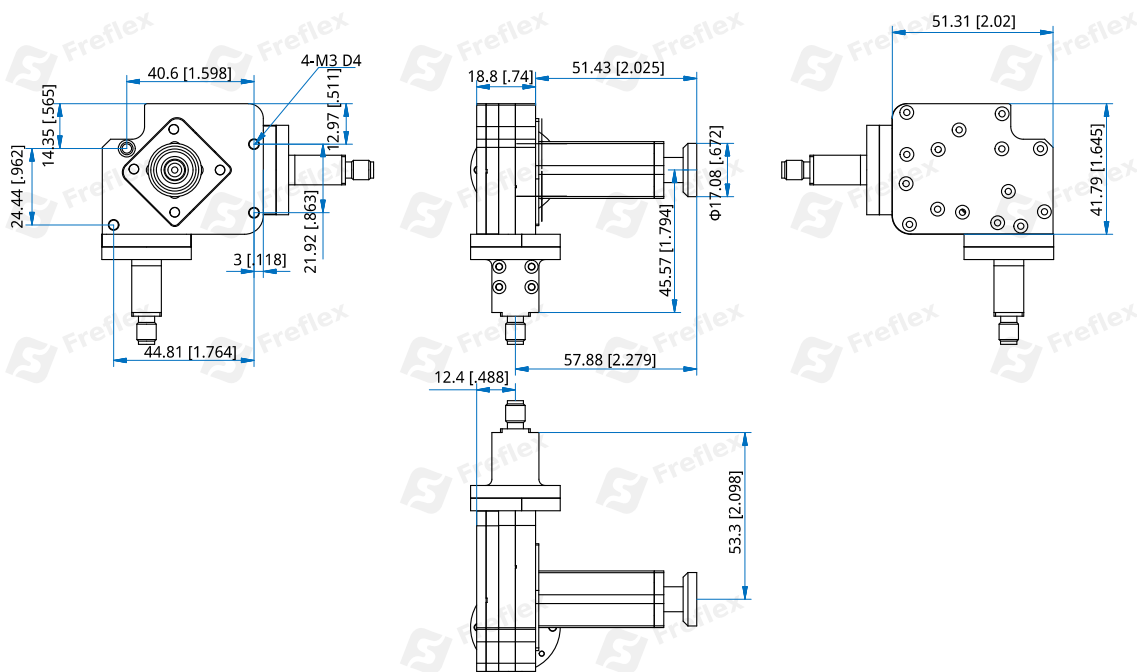

Unit: mm [in]

Tolerance: $\pm 0.5\text{mm}$ [$\pm 0.02\text{in}$]

How To Order

[FDPHA-33000-50000-10-2-1](#)

Customization is available upon request.