

FLA-100-6000-16-10

100~6000MHz, 16dB, 1dB

Features:

- * Small Size
- * Low Power Consumption

Applications:

- * Wireless
- * Transmitter
- * Laboratory Test

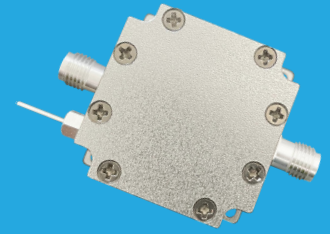

Electrical

Frequency:	100~6000MHz
Gain:	16dB typ.
Gain Flatness:	±8dB typ.
Noise Figure:	1dB typ.
Output Power (P1dB):	21dBm typ.
Input VSWR:	2 typ.
Output VSWR:	2 typ.
Voltage:	+5V DC
Impedance:	50Ω

Absolute Maximum Ratings*1

RF Input Power:	22dBm
Voltage:	+7V

[1] Permanent damage may occur if any of these limits are exceeded.

Mechanical

Size*2:	30*30*15mm 1.181*1.181*0.591in
RF Connectors:	SMA female
Power Supply Connectors:	Feed Through/Terminal Post
Mounting:	4-Φ2.2mm through-hole

[2] Exclude connectors.

Environmental

Operating Temperature:	-40~+85°C
------------------------	-----------

Outline Drawings

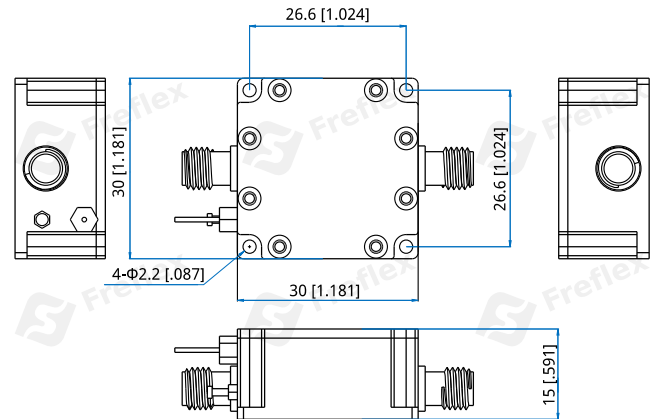

Unit: mm [in]

Tolerance: ±0.2mm [±0.008in]

How To Order

FLA-100-6000-16-10

Customization is available upon request.

Typical Performance Curves

Input VSWR vs. Frequency

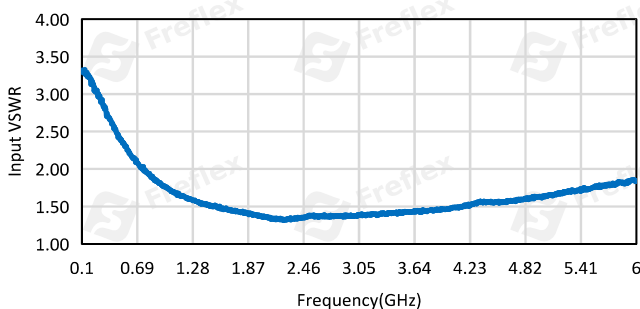

Output VSWR vs. Frequency

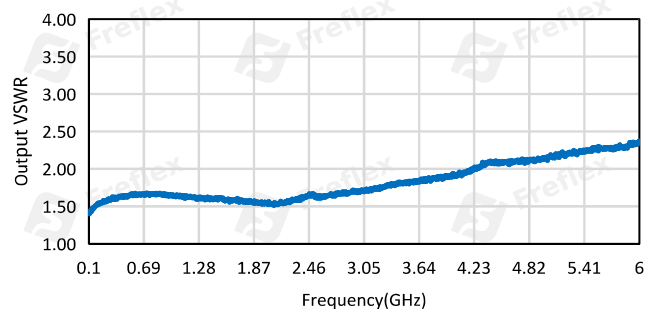

Low Noise Amplifier

Gain vs. Frequency

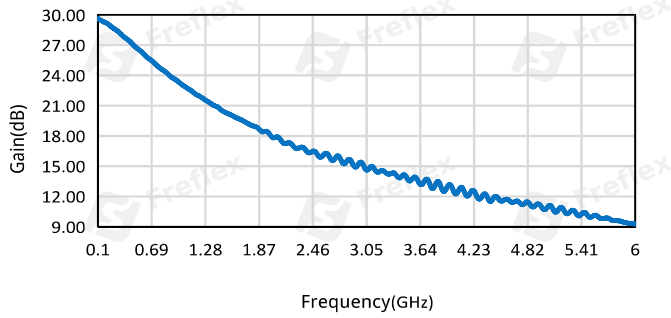

Noise Figure vs. Frequency

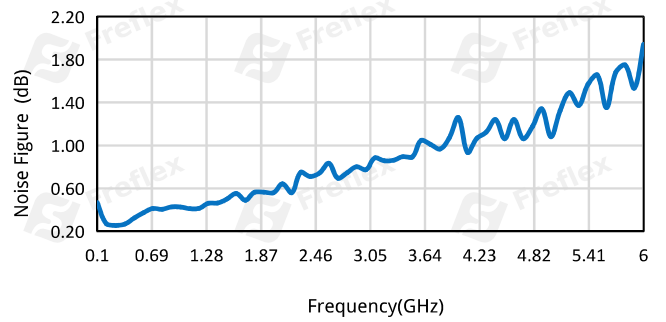

P1dB vs. Frequency

