

FMP2-20-8000-1

0.02GHz, 8GHz

Features:

- * High Stopband Rejection
- * Small Size

Applications:

- * Telecom
- * Laboratory Test
- * Transceivers
- * Instrumentation

Electrical

Channel 1 (L):	0.02~0.8GHz
Channel 2 (H):	0.93~8GHz
Passband Insertion Loss:	2dB max. @0.02~0.8GHz 2.5dB max. @0.93~8GHz
Rejection (CH L):	45dB min. 0.02~0.8GHz@0.95~8GHz
Rejection (CH H):	45dB min. 0.93~8GHz@0.02~0.75GHz
VSWR:	2 max.
Power:	1W
Impedance:	50Ω

Mechanical

Size*1:	60*60*20mm 2.362*2.362*0.787in
RF Connectors:	N Female
Mounting:	4-Φ3.5 through-hole

[1] Exclude connectors.

Environmental

Operating Temperature:	-40~+70°C
------------------------	-----------

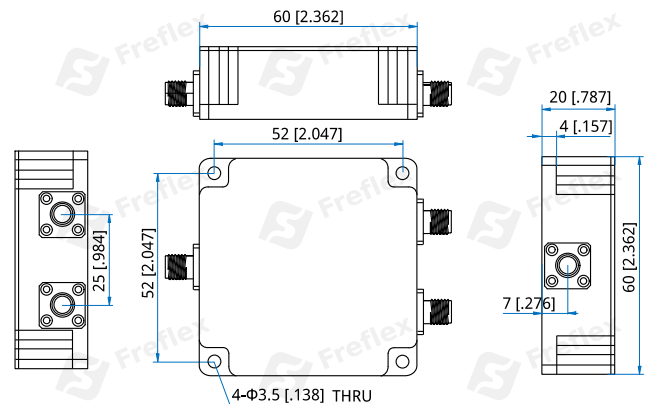
Outline Drawings

Unit: mm [in]

Tolerance: ±0.5mm [±0.02in]

How To Order

FMP2-20-8000-1

Customization is available upon request.