

# FPS2-1000-18000-A-5

## SPDT, 1~18GHz, Absorptive

**Features:**

- \* Low Insertion Loss
- \* High Isolation

**Applications:**

- \* Wireless
- \* Transmitter
- \* Laboratory Test
- \* Radar

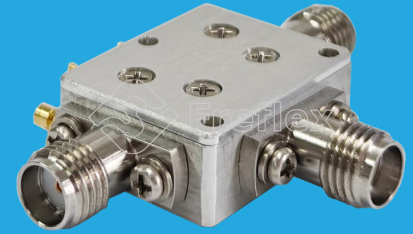
**Electrical**

Frequency:	1~18GHz
Insertion Loss:	3dB max.
Isolation:	30dB min.
VSWR (On state):	1.4 typ.
Input Power (P1dB):	24dBm typ.
Switching Time:	25ns typ.
Voltage:	+5V DC typ.
Current:	10mA typ.
Control:	High - 1 @2.5~5V Low/NC - 0 @0~0.8V

**Absolute Maximum Ratings\*1**

RF Input Power:	27dBm
Control Voltage:	+5.5V

[1] Permanent damage may occur if any of these limits are exceeded.

**Mechanical**

Size*2:	20*16*8mm 0.787*0.63*0.315in
RF Connectors:	SMA female (Removable)
Power Supply Connectors:	Feed through/Terminal post
Mounting:	3-Φ1.8mm through-hole

[2] Exclude connectors.

**Environmental**

Operating Temperature:	-45~+85°C
Non-operating Temperature:	-55~+125°C

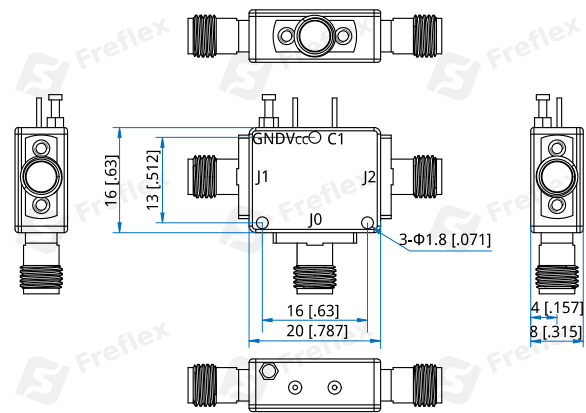
**Outline Drawings**

Unit: mm [in]

Tolerance: ±0.2mm [±0.008in]

**Control True Table**

C1	Connection
0	J0 - J1 On
1	J0 - J2 On

**How To Order**

**FPS2-1000-18000-A-5**

Customization is available upon request.

## Typical Performance Curves

